

E8 3/8" Plastic Pumps Specifications and Performance

SPECIFICATIONS

E8

FLOW RATE adjustable to.....0-6.8 gpm (26 lpm)

PORT SIZE

Inlet and Outlet 3/8" NPTF (BSP)

AIR INLET 0.25" NPT

AIR EXHAUST 0.25" NPT

SUCTION LIFT (dry)11' (3.4 m)

Teflon® (dry)11' (3.4 m)

MAX. PARTICLE SIZE (Dia.) 0.10" (2.5 mm)

SHIPPING WEIGHT

Polypropylene 3.0 lbs (1.4 kg)

Kynar..... 3.0 lbs (1.4 kg)

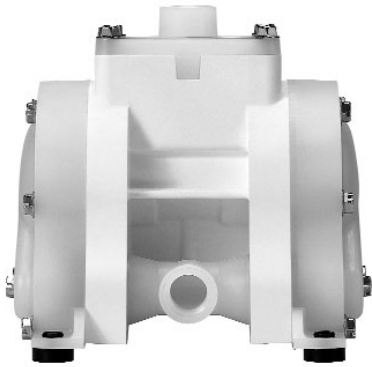

PERFORMANCE

Determined by actual flow meter tests.

E8

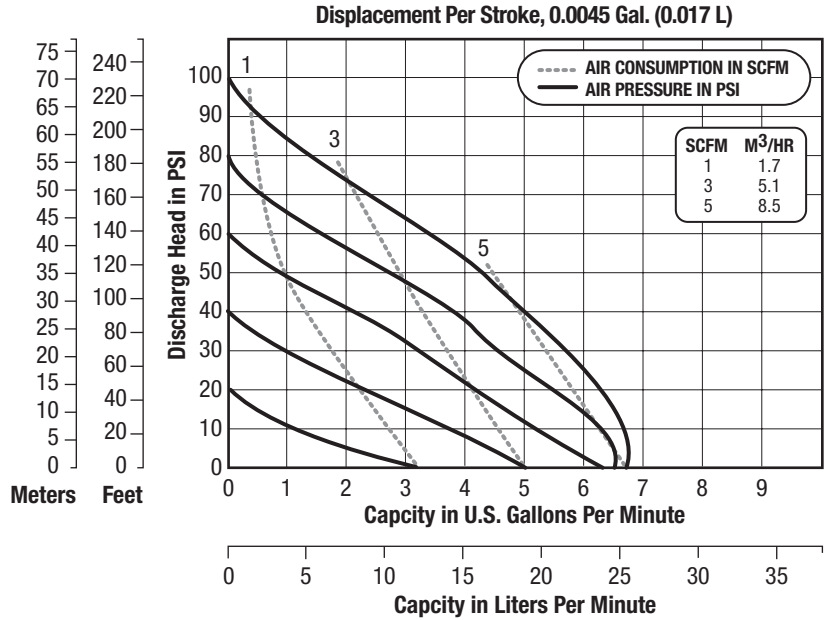

CAUTION: Do not exceed 100 psig (6.8 bars) air supply or liquid pressure.

DIMENSIONS Consult factory for certified drawings.

E8

